

FRESATRICE CN PER SERRAMENTI
FRAISEUSE CN POUR PORTES ET FENÊTRES
NC MILLING MACHINE FOR JOINERY COMPONENTS AND DOORS
FRESADORA CN PARA PUERTAS Y VENTANAS



Alfa



Alfa

La nuova fresatrice automatica ALFA con 3 assi a controllo numerico è concepita con le più recenti soluzioni tecniche quali:

- movimentazione assi interpolati con motori brushless
- viti a ricircolo di sfere
- guide lineari con pattini a ricircolo di sfere

La macchina permette lavorazioni rapide e accurate su montanti o telai di finestra, porte ed anche componenti di scale e mobili in genere.

Grazie al controllo grafico Touch-Screen con porta USB, la programmazione e messa a punto sono particolarmente semplici e intuitive consentendo un cambio di lavorazione estremamente veloce. Un altro notevole vantaggio dell'ALFA è la grande capacità di lavoro - in totale automatismo - che permette fresature fino a 2800 mm di lunghezza sia a 0° che a 90°. Tutto ciò è ottenuto su una macchina solida e di dimensioni assai contenute.

ALFA è disponibile in diverse configurazioni:

- * con gruppo fresa (versione base)
- * con gruppo fresa + unità a fresare supplementare per esecuzione di mostrine quadre o rettangolari e per decorazioni su porte
- * con gruppo fresa + gruppi di lavoro per anubatura

L'ALFA, in versione non CE, viene fornita senza barriere ottiche laterali e senza cella di protezione posteriore.

La nouvelle fraiseuse automatique ALFA à 3 axes à contrôle numérique est conçue sur la base des plus récentes solutions techniques comme:

- déplacement des axes interpolés avec moteurs brushless
- vis à circulation de billes
- guides linéaires avec patins à circulation de billes

La machine permet des usinages rapides et soignés sur des montants ou des châssis de fenêtres, de portes et autres éléments d'escaliers et de meubles en général.

Grâce au contrôle graphique écran tactile avec porte USB, la programmation et la mise au point sont particulièrement simples et intuitives et permettent un changement d'usinage extrêmement rapide. Une autre importante qualité de la fraiseuse ALFA consiste dans sa grande capacité productive - totalement automatique - qui permet des fraisages jusqu'à 2800 mm de longueur aussi bien à 0° qu'à 90°. Le tout réuni sur une machine solide et aux dimensions très réduites.

ALFA est disponible en versions différentes:

- * avec unité de fraisage (version de base)
- * avec unité de fraisage + groupe de fraisage supplémentaire pour mortaises de la têtère carrées ou rectangulaires et pour décorations sur les portes
- * avec unité de fraisage + groupe pour fiches Anuba

L'ALFA, dans la version non CE, est livrée sans barrières optiques latérales et sans cellule de protection arrière.



The new ALFA NC milling machine with 3 axes has been developed with following high technical solutions:

- interpolated axes powered by brushless motors
- re-circulating ball screws
- linear guides with ball runner blocks

The machine is extremely versatile and suitable for a variety of milling operations on window frames or door stiles, as well as on stair and furniture components.

It ensures quick and precise operations at all times.

The touch-screen controller with USB key is very simple and quick to use and makes programming very easy.

ALFA also offers a big milling capacity of up to 2800 mm in length at either 0° or 90°. The machine is also very heavy and compact.

ALFA is available in different configurations:

- * with milling unit (basic version)
- * with milling unit + additional milling unit for square or rectangular face plate slots and for decorations on doors
- * with milling unit + Anuba hinges unit

The ALFA machine, in non CE-version, is supplied without side optical barriers and without rear safety guard.

La nueva fresadora automática ALFA con 3 ejes a control numérico es concebida con las más recientes soluciones técnicas que son:

- desplazamiento de los ejes interpolados con motores brushless
- tornillos a recirculación de esferas
- guías lineares con patines a recirculación de esferas

La máquina permite trabajos rápidos y exactos sobre montantes o marcos de ventanas, puertas y también componentes de escaleras o muebles en general.

Gracias al control gráfico Touch Screen con puerta USB, la programación y la puesta a punto son particularmente simples y intuitivas consintiendo un cambio de elaboración extremadamente veloz. Otra notable ventaja de ALFA es la gran capacidad de trabajo en total automatismo que permite fresados hasta de 2800 mm de longitud ya sea a 0° que a 90°. Todo esto se obtiene sobre una máquina sólida y de pequeñas dimensiones.

ALFA está disponible in distintas configuraciones:

- * con cabezal fresador (versión básica)
- * con cabezal fresador + cabezal fresador suplementario para canteras cuadradas o rectangulares para bisagras y para decoraciones sobre puertas
- * con cabezal fresador + grupos de trabajo para bisagra Anuba

ALFA, sin CE normas, no está equipada con fotoceldas laterales y protección posterior.



Alfa

- 1 - Programmazione semplice e intuitiva grazie al controllo grafico Touch Screen che utilizza macro pre-installate.
- 2 - Possibilità di eseguire fresature - in modo automatico - sia sul piano verticale che orizzontale su montanti o su porte e finestre.
- 3 - Il gruppo fresa programmabile consente molteplici lavorazioni, comprese cave per persiane e cerniere in genere.
- 4 - Ferramenta per porte, finestre e telai
- 5 - Esempi di fresatura su telai di finestra.

- 1 - Programmation simple et intuitive grâce au contrôle graphique écran tactile qui utilise des macro prédéterminées.
- 2 - Possibilité d'effectuer des fraisages - en mode automatique - aussi bien sur le plan vertical qu'horizontal sur des montants ou sur des portes et des fenêtres.
- 3 - L'unité de fraisage programmable permet plusieurs usinages, y compris ceux pour les persiennes et les charnières en général.
- 4 - Quincaillerie pour portes, fenêtres et montants .
- 5 - Exemples de fraisage sur des châssis de fenêtre.

- 1 - Touch-screen controller with pre-installed macros for easy programming.
- 2 - Possibility of automatic vertical and horizontal millings on beams or windows and door frames.
- 3 - The programmable milling unit is extremely flexible and can perform a number of machining operations including jalousie window slots and hinge recessing.
- 4 - Hardware for doors, windows and frames.
- 5 - Examples of milling on window frames.

- 1 - Programación simple y intuitiva gracias al control gráfico de la Pantalla Táctil que utiliza macros predeterminadas.
- 2 - Posibilidad de realizar fresaduras - en modo automático - ya sea sobre el plano vertical que horizontal sobre montantes o sobre puertas y ventanas.
- 3 - El grupo fresa programable admite múltiples elaboraciones, incluidas las ranuras para persianas y bisagras en general.
- 4 - Cerraduras para puertas, ventanas y marcos.
- 5 - Ejemplos de fresado sobre marcos de ventana.

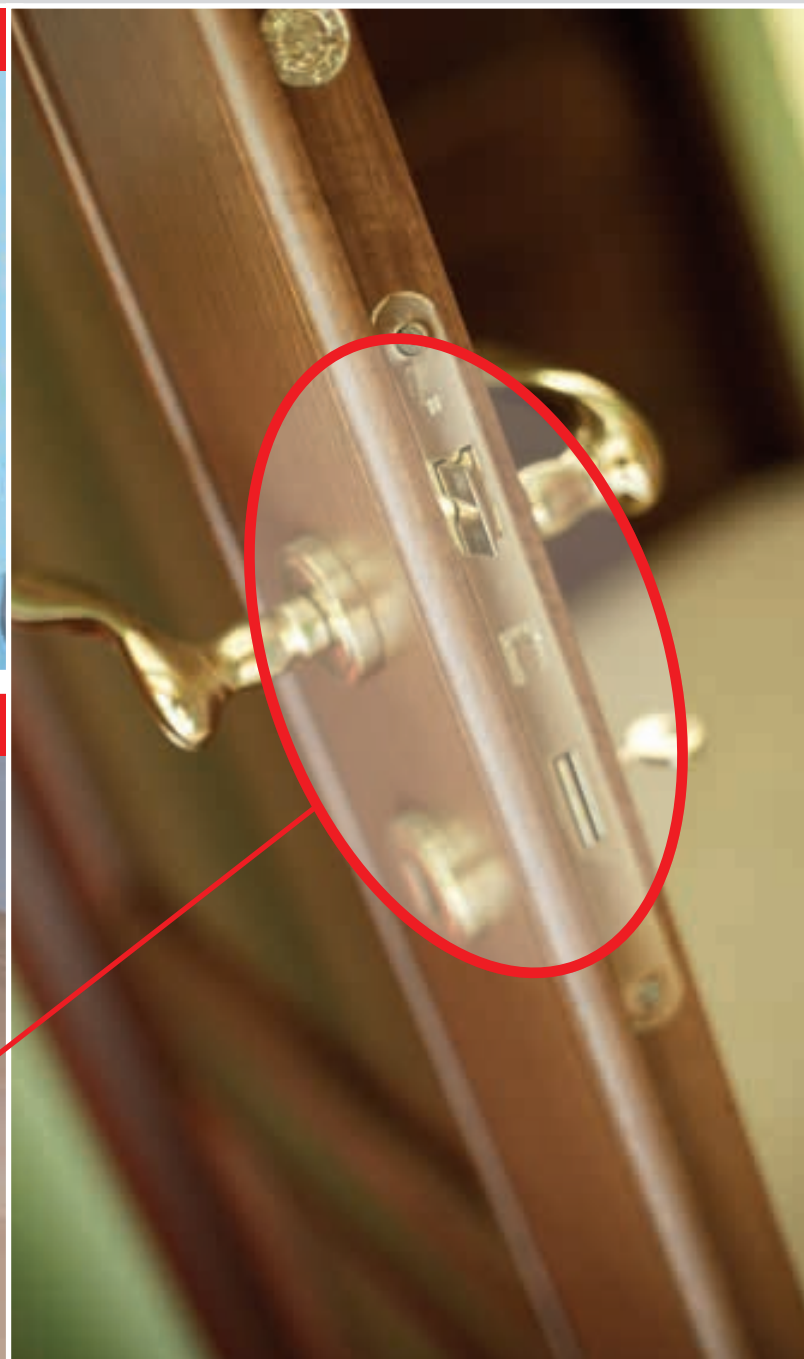

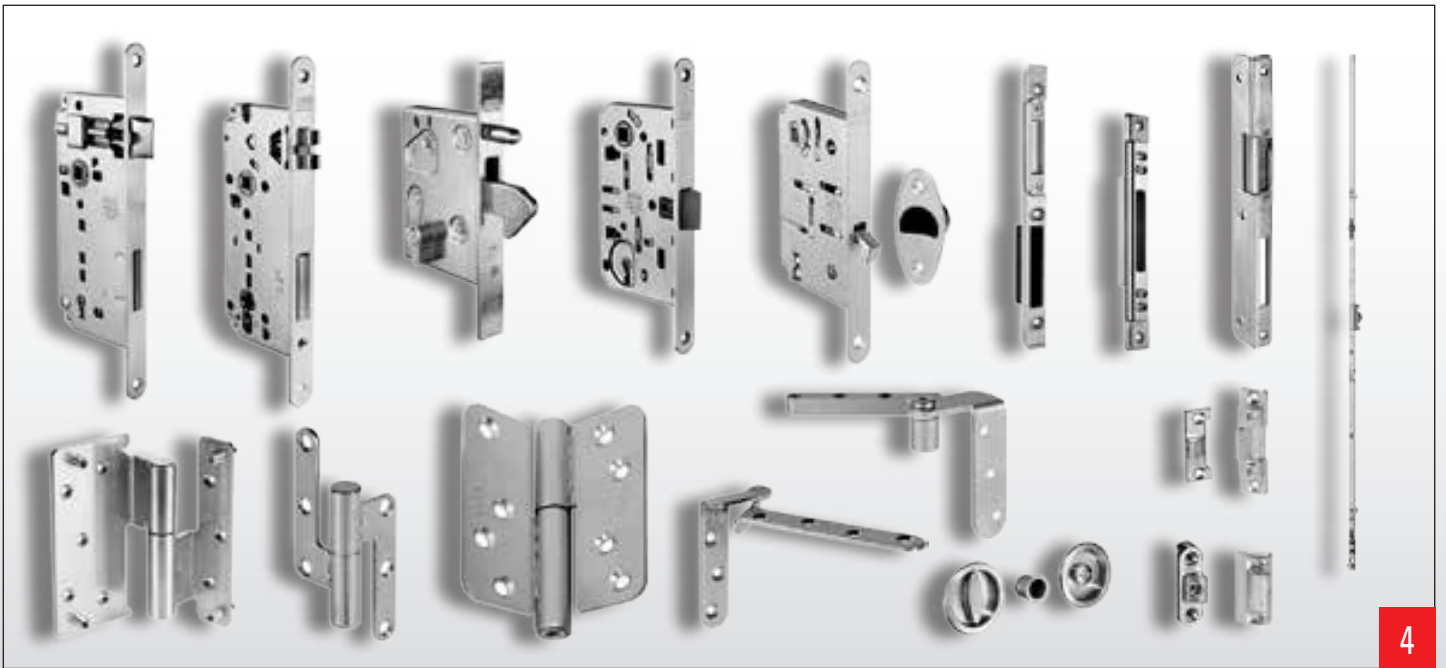

4



3



5

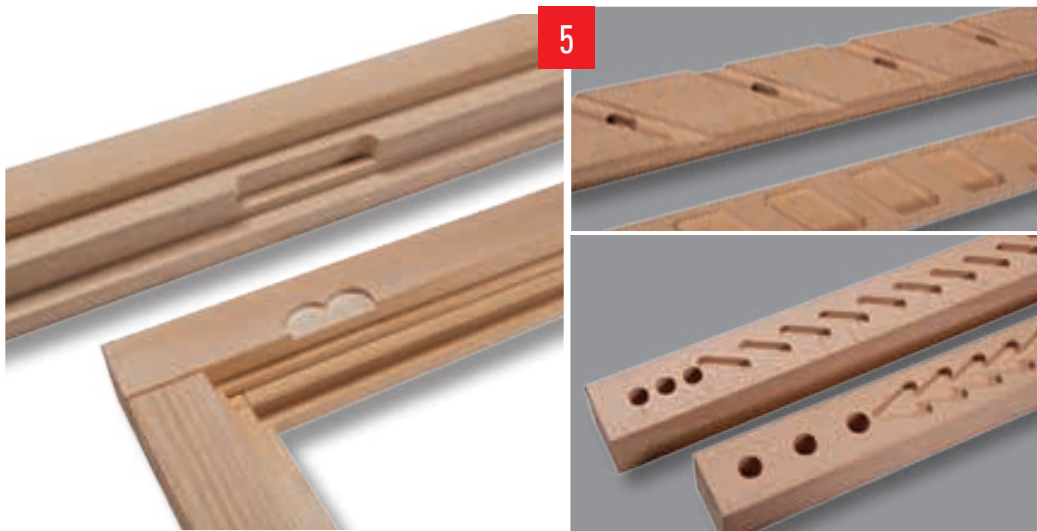

Alfa

OPZIONALI OPTION OPTIONS OPCIONALES

- A - Capacità asse Y 400 mm
- B - Cambio rapido utensili: ISO30 a comando pneumatico (su motore fresa standard KW 3,3) completo di 2 porta- utensili
Cambio rapido utensili: HKS40 sistema meccanico (su motore fresa opzionale KW 5,6) completo di 2 porta-utensili
- C - Pianetto anteriore a forare, rientrante
- D - Dispositivo di sollevamento e rotazione porta

- A - Capacité axe Y 400 mm
- B - Changement rapide outils: ISO30 à commande pneumatique (sur moteur fraise standard KW 3,3) complete avec 2 porte-outils
Changement rapide outils: HKS40 système mecanique (sur moteur fraise option KW 5,6) complete avec 2 porte-outils
- C - Table de perçage frontale, escamotable
- D - Dispositif de levage et rotation de la porte

- A - Y axis capacity 400 mm
- B - Rapid tool change: ISO30 pneumatically controlled (on standard router motor KW 3,3) c/w 2 toolholders
Rapid tool change: HKS40 mechanical system (on optional router motor KW 5,6) c/w 2 toolholders
- C - Front retractable table for end boring
- D - Lifting and turning door device

- A - Capacidad eje Y 400 mm
- B - Cambio rapido herramientas: ISO30 a comando neumatico (con motor standard KW 3,3) completo de 2 porta-herramientas
Cambio rapido herramientas: HKS40 sistema mecanico (con motor fresa opcional KW 5,6) completo de 2 porta-herramientas
- C - Mesa anterior para taladrar, entrante
- D - Mesa rotante neumatica para elevar y girar la puerta

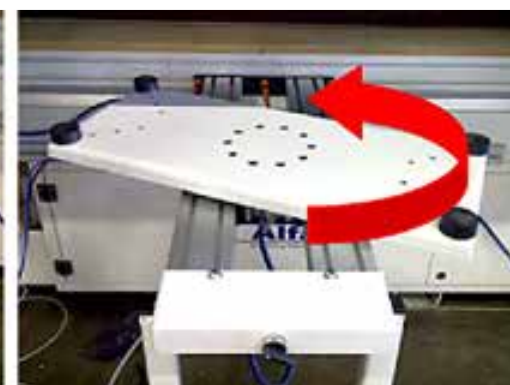
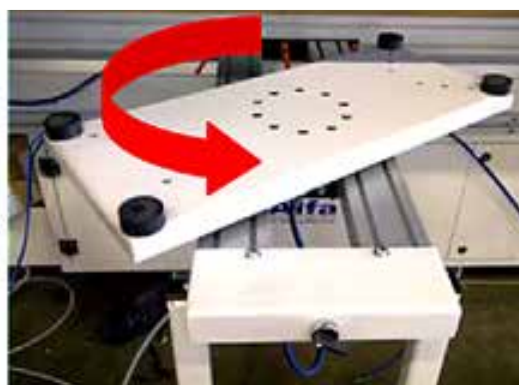
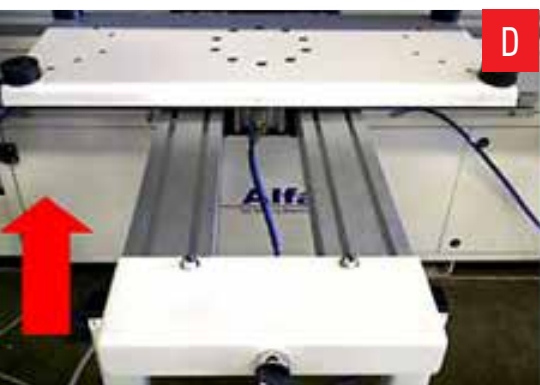

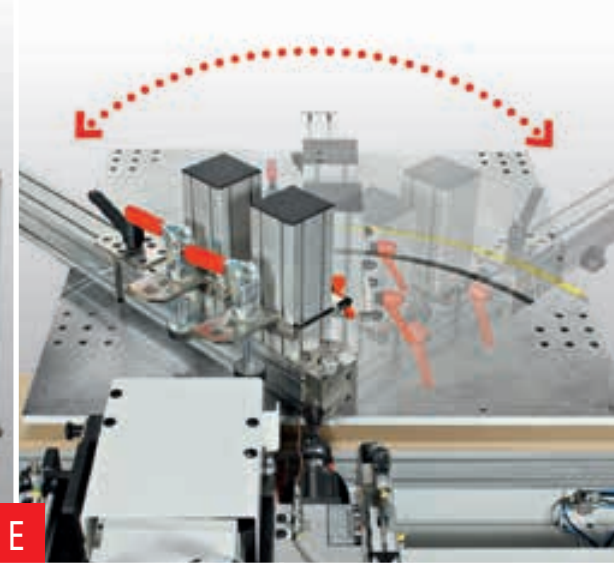

E

- E - Tavolo per fresature a coda di rondine e tenoni
- F - Unità a fresare supplementare kW 2,2 con pinza ER25 e fresa diam. 3 mm
- G - Software per importazione file ISO e licenza ArtCam Express



- E - Table pour fraisages à queue d'aronde et tenons
- F - Unité de fraisages supplementarie kW 2,2 avec pince ER25 et fraise diam. 3 mm
- G - Logiciel importation fichier ISO et licence ArtCam Express



- E - Special table for dovetail millings and tenons
- F - Additional milling unit kW 2,2 c/w ER25 collet and cutter 3 mm diam.
- G - Software package for ISO file import and ArtCam Express licence



- E - Mesa de trabajo para fresadura coda di rondine y espigas
- F - Electromandril suplementario kW 2,2 con pinza ER25 y fresa diam. 3 mm
- G - Software importación archivos ISO y licencia ArtCam Express



F



G



- G** - Unità a forare kW 0,75; 4500 G/Min
 - Completamente programmabile permette l'esecuzione di fori per cerniere Anuba su porte, finestre e telai.
 - Inclinazione -10° +90° manuale

- G** - Unité de perçage - kW 0,75; 4500 T/Min
 - Complètement programmable permet l'exécution de trous pour fiches Anuba sur portes, fenêtres et montants.
 - Inclination -10° +90° manuelle

- G** - Drilling unit kW 0,75; 4500 R/Min
 - Fully programmable allows to drill holes for Anuba hinges in doors, windows and frames.
 - Manual inclination -10° +90°

- G** - Unidad a taladrar kW 0,75; 4500 G/Min
 - Totalmente programable permite la ejecución de agujeros para bisagras Anuba sobre puertas, ventanas y marcos.
 - Inclinación -10° +90° manual



H

- 1 - Unità a forare
 1 - Unité de perçage
 1 - Drilling unit
 1 - Unidad a taladrar

- 2 - Unità ad avvitare
 2 - Unité de vissage
 2 - Screwing device
 2 - Unidad para atornillar

- 3 - Posizionamento automatico Anuba
 3 - Positionnement automatique fiches Anuba
 3 - Automatic positioning Anuba hinges
 3 - Posicionamiento automatico Anuba

- 4 - Caricatore cerniere Anuba
 4 - Chargeur pour fiches Anuba
 4 - Loading device for Anuba hinges
 4 - Cargador para bisagras Anuba

- 5 - Sistema di regolazione della profondità di avvitatura
 5 - Système de régulation de la profondeur de vissage
 5 - Screwing depth regulating system
 5 - Sistema de regulación de la profundidad de atornilladura

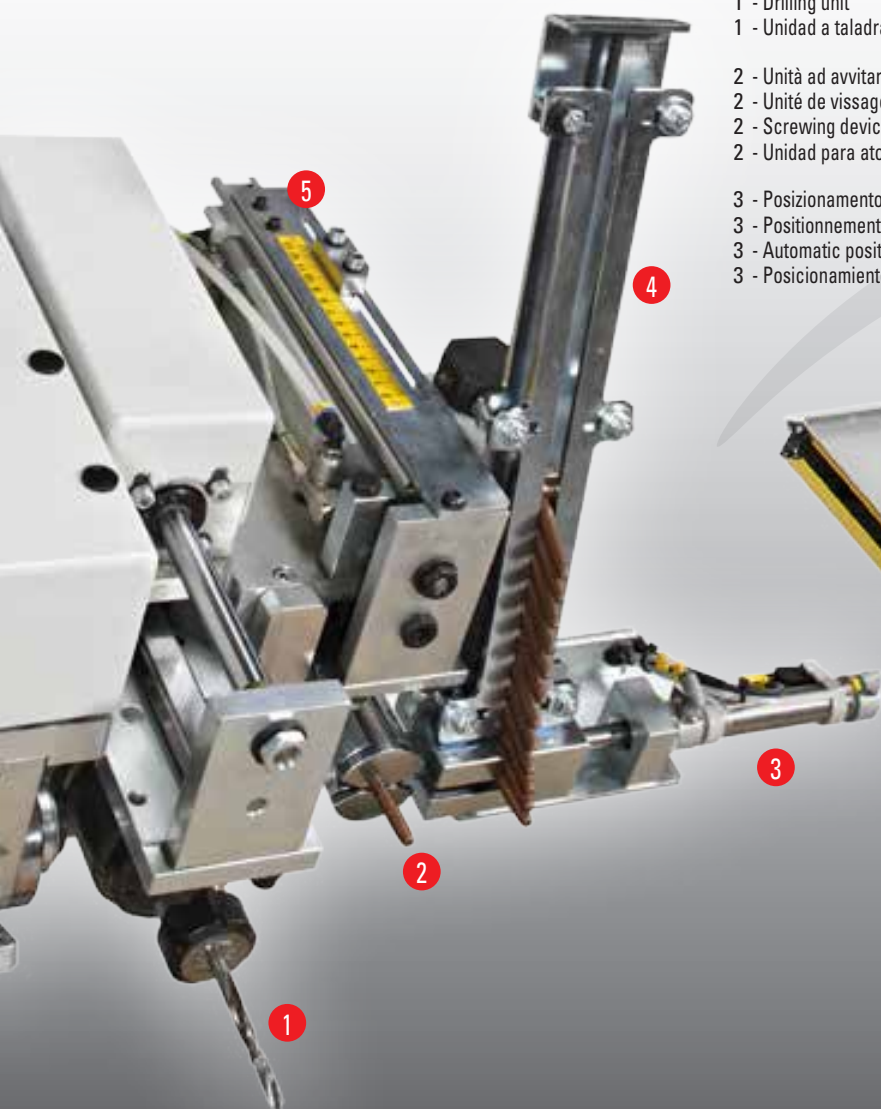

CEP



- H - Gruppo di anubatura**
- Completamente programmabile da CN permette la foratura e l'inserimento di cerniere Anuba su porte, finestre e telai
 - Elettromandrino kW 2,2; 18000 G/Min o in alternativa Unità a forare kW 0,75; 4500 G/Min
 - Unità di avvitatura gestito da motore Brushless
 - Caricatore automatico per cerniere Anuba.
 - Inclinazione $-10^{\circ} + 90^{\circ}$ controllata da CN

- H - Groupe pour fiches anuba**
- Complètement programmable par CN permet le perçage et vissage de fiches anuba sur portes, fenêtres et châssis
 - Unité de fraisage Kw 2,2; 18000 T/Min ou unité de perçage kW 0,75; 4500 T/Min
 - Unité de vissage géré par moteur Brushless
 - Chargeur automatique pour fiches Anuba.
 - Inclinaison $-10^{\circ} + 90^{\circ}$ contrôlée par CN

- H - Anuba hinges unit**
- Fully programmable by CN allows drilling and inserting of anuba hinges on doors, windows and frames
 - Milling unit kW 2.2; 18000 R/Min or alternatively Drilling unit kW 0,75; 4500 R/Min
 - Screwing device operated by Brushless motor
 - Automatic loading device for Anuba hinges.
 - Inclination $-10^{\circ} + 90^{\circ}$ controlled by CN

- H - Grupo de trabajo para bisagra anuba**
- Totalmente programable por CN permite de taladrar/atornillar bisagras anuba sobre puertas, ventanas y marcos
 - Electromandril kW 2,2; 18000 G/Min o en alternativa Unidad a taladrar kW 0,75; 4500 G/Min
 - Unidad para atornillar operado por un motor Brushless
 - Cargador automatico para bisagras Anuba.
 - Inclinación $-10^{\circ} + 90^{\circ}$ controlada por CN



INCLINAZIONE STANDARD 0° + 90°
INCLINAISON STANDARD 0° + 90°
TILTING 0° + 90° STANDARD
INCLINACIÒN STANDARD 0° + 90°

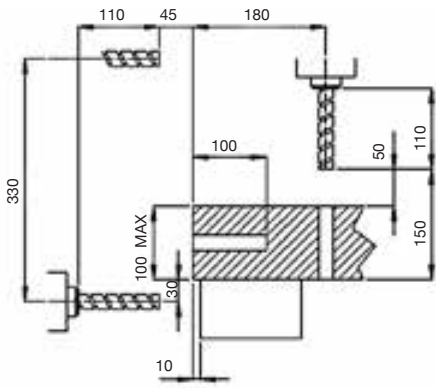

Fresa standard
 Fraise standard
 Standard milling unit
 Grupo fresa standard

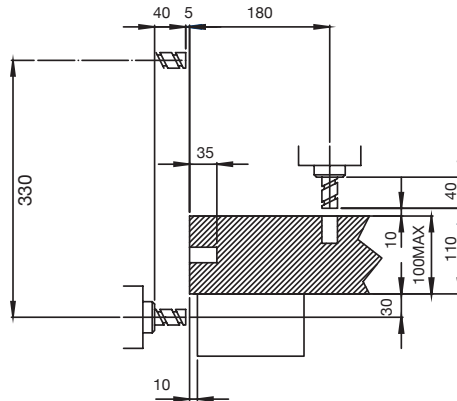

Fresa supplementare
 Fraise supplémentaire
 Additional milling unit
 Grupo fresa suplementario

INCLINAZIONE -10° +90° CONTROLLATA
INCLINAISON -10° +90° CONTRÔLÉE
TILTING -10° +90° CONTROLLED
INCLINACIÒN -10° +90° CONTROLADA

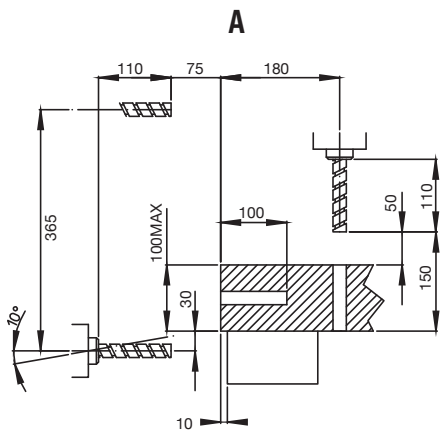

Fresa standard
 Fraise standard
 Standard milling unit
 Cabezal fresador standard

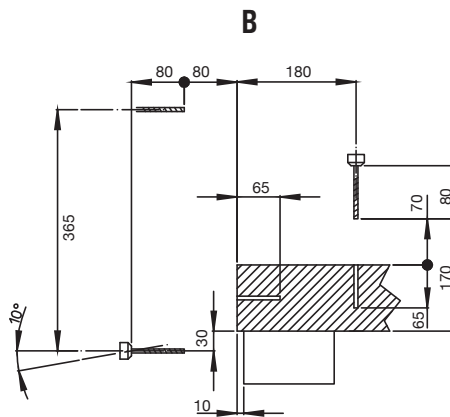

Fresa supplementare / Unità a forare
 Fraise supplémentaire / Unitè de perçage
 Additional milling unit / Drilling unit
 Cabezal fresador suplementario / Unidad a taladrar

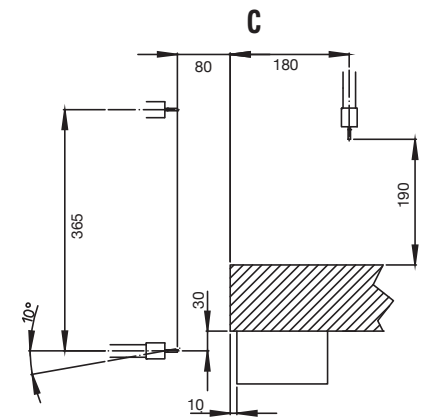

Unità di avvitatura
 Unitè de vissage
 Screwing device
 Unidad para atornillar

CORSE UTILI ASSE X
CAPACITÉ AXE X
STROKE X AXIS
RECORRIDO EJE X

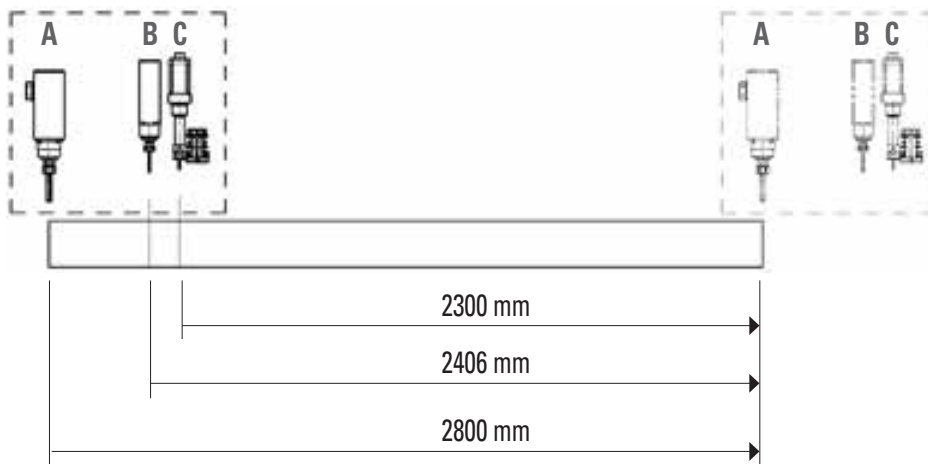

DATI TECNICI • DONNÉES TECHNIQUES • TECHNICAL DATA • DATOS TECNICOS

• Capacità utile assi X-Y-Z (fresa) • Capacité axes X-Y-Z (fraise) • Axis output X-Y-Z (milling unit) • Capacidad ejes X-Y-Z (fresa)	mm	2800 180(400*) 150
• Pinza ER32 per fresa Ø 16-15 mm • Pince ER32 pour fraise Ø 16-15 mm • ER32 collet for milling cutter 16-15 mm Ø • Ataque ER32 para fresa Ø 16-15 mm	nr.	1
• Velocità max assi X-Y-Z • Vitesse max. axes X-Y-Z • X-Y-Z axis speed • Velocidad maxima ejes X-Y-Z	mt./mm	35 / 7,5 / 7,5
• Dimensioni max. piano di lavoro • Dimensions max. table de travail • Max. working table dimensions • Dimensiones max. mesa de trabajo	mm	3000 x 618
• Battute posteriori rientranti • Butées posterieures escamotables • Retractable rear stops • Topes traseros entrantes	nr.	2
• Pressori anteriori • Presseurs antérieurs • Front clamps • Prensaes anteriores	nr.	3
• Battute laterali (1 sx - 1 dx) • Butées laterales (1 droite - 1 gauche) • Side stops (1 RH - 1 LH) • Topes laterales (1 derecho - 1 izquierdo)	nr.	2
• Prolunghe frontali di appoggio pezzo • Rallonges frontales d'appui de la pièce • Front table extensions for piece support • Prolonga frontal de apoyo puerta	nr.	2
• Potenza elettromandrino fresa • Puissance electro-mandrin de la fraise • Router motor power • Potencia electromandril fresa	kW	3,3 (5,6*)
• Velocità elettromandrino programmabile • Vitesse electro-mandrin programmable • Programmable router motor speed • Velocidad electromandril programable	g./min	0 - 18000
• Potenza elettromandrino fresa supplementare • Puissance electro-mandrin de la fraise supplementaire • Additional router motor power • Potencia electromandril fresa suplementaria	kW	2,2 *
• Velocità elettromandrino fresa supplementare programmabile • Vitesse electro-mandrin de la fraise supplementaire • Additional router motor speed • Velocidad electromandril fresa suplementario	g./min	0 - 18000
• Inclinazione fresa • Inclinaison de la fraise • Inclination of router head • Inclinación fresa		0° / 90° (-10° +90° *)
• Potenza unità a forare • Puissance unité de perçage • Drilling unit motor power • Potencia unidad a taladrar	kW	0,75 *
• Velocità unità a forare • Vitesse unité de perçage • Drilling unit motor speed • Velocidad unidad a taladrar	g./min	4500 *
• Inclinazione unità a forare • Inclinaison du unité de perçage • Inclination of drilling unit • Inclinación unidad a taladrar		-10° / +90° *
• Rotazione unità di avvitatura • Rotation unité de vissage • Rotation of screwing device • Rotación unidad para atornillar	g./min	0 - 375 *
• Programmatore elettronico Power 1000 • Programmeur électronique Power 1000 • Electronic control Power 1000 • Programador electronico Power 1000		Touch Screen 10"
• Bocche aspirazione • Buses d'aspiration • Dust extraction outlets • Boca de aspiracion	nr.	1 ø 80 mm 2 ø 100 mm
• Pressione d'esercizio impianto • Pression de service • Operating pressure • Prension de servicio	bar	6 (Lit/min. 300)
• Peso netto • Poids net • Net weight • Peso neto	Kg	1300

* opzionale / sur demande / optional / Opcional

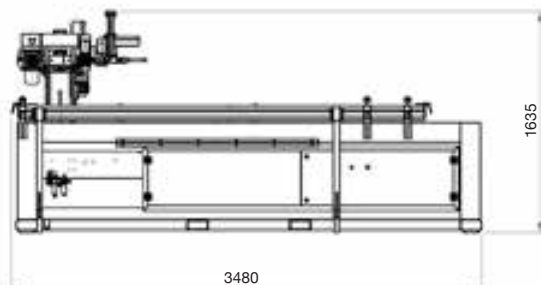
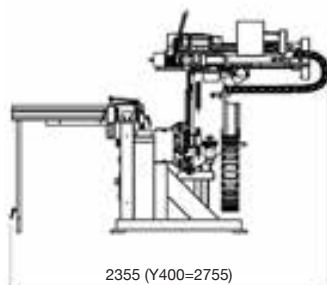

Ingombro macchina NON CE
 Encombrement machine NO CE
 Overall dimensions NO CE
 Dimensiones máquina NO CE

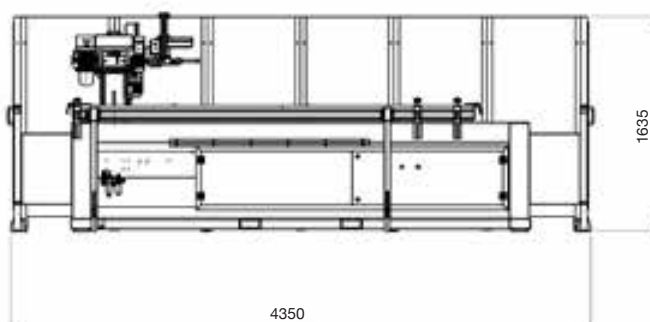
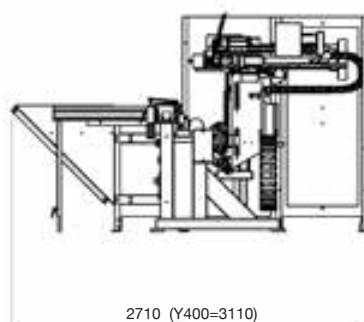

Ingombro macchina CE
 Encombrement machine CE
 Overall dimensions CE
 Dimensiones máquina CE

centauro



Centauro S.p.A.
41010 Limidi (Modena) Italy
Via Carpi Ravarino, 87
Tel. 059 855411 - Fax 059 561109
centauro@centaurospa.it
www.centaurospa.it